

DESCH Flex

Flexible Couplings



DF 12 - GB

Flexible DESCH Flex-couplings

DESCH Flex shaft couplings

The DESCH Flex coupling combines all the advantages which can be expected of an ideal flexible coupling. Additionally it is suitable for taper bushes. The DESCH-Flex coupling is a torsional flexible coupling which offers a wide spectrum of cases of applications to the technical designers and the engineers by combining the different types of steel flanges for many different applications. The flanges are offered for assembling with taper bush or final bored.

DESCH Flex is a high flexible tyre-coupling which can because of the special builded tyre take an extreme big misalignment at a low restoring force in each direction without noticing this in the wear. Because of a factory-installed joint the tyre can according to standard be radially assembled and disassembled without shifting the connected engines. The transmission of the torque takes place absolutely free from backlash. It is suitable to take up torsional impacts and to damp arising vibrations. The tyre with fabric inside is either made of natural rubber or of Neoprene in fire-resistant, antistatic and oil-resistant execution, short called FRAS-Execution. The FRAS-tyre is also used in duties with EX-Operations according to the regulations 94/9/EG (ATEX). Tyres made of natural rubber are suitable for ambient temperatures between -50°C and +50°C. Tyres in FRAS-Execution are suitable for ambient temperatures between -15°C and +70°C.



Type

- > Standard coupling for finish bore
- > Execution for Taper-bush
- > Combined standard/Taper execution
- > Components can be combined as needed.

Flexible DESCH Flex coupling with taper bush

DESCH Flex coupling combines the advantages of the elastic couplings with those of the taper bush system: fast and simple assembly of a torsionally flexible connection of shafts and compensation for shaft alignment errors. DESCH Flex couplings with taper bush have the advantage that even with greater shaft tolerances there is a backlash-free and at the same time axial fixing of the shaft. In addition the close sliding fit makes axial alignment of the coupling easier.

DESCH Flex Flange B, F, H

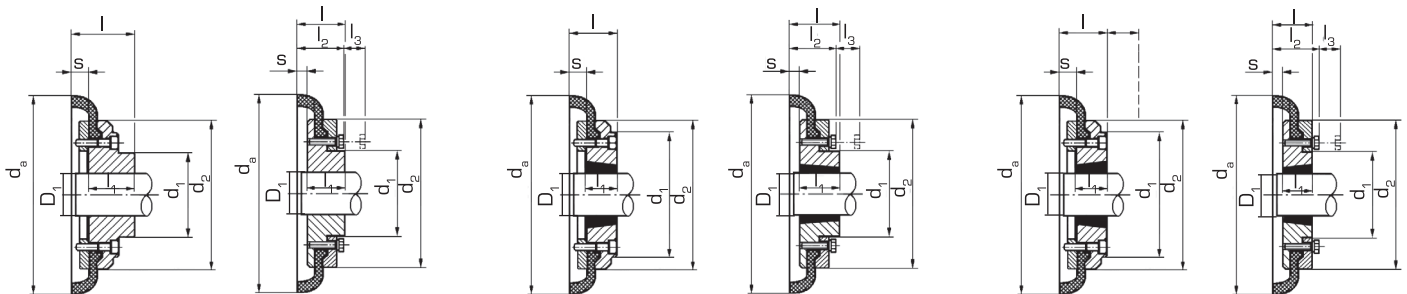

> B Flange
40-60

70-250

> F Flange
40-60

70-250

> H Flange
40-60

70-250

Size	pre-bored	B Flange				F Flange				H Flange										
		D_1 (H7) ¹⁾	d_1	l	l_1	bush	D_1	d_1	l	l_1	bush	D_1	d_1	l	l_1	d_a	d_2	l_2	l_3	s
		max. mm	mm	mm	mm		max. mm	mm	mm	mm		mm	max. mm	mm	mm	mm	mm	mm	mm	mm
D 40	12	30	-	33	22	1008	25	-	33	22	1008	25	-	33	22	104	82	-	-	11
D 50	15	38	79	45	32	1210	32	79	38	25	1210	32	79	38	25	133	100	-	-	12,5
D 60	18	45	70	55	38	1610	42	70	42	25	1610	42	70	42	25	165	125	-	-	16,5
D 70	22	50	80	47	35	2012	50	80	44	32	1610	42	80	42	25	187	144	50	13	11,5
D 80	25	60	97	55	42	2517	60	95	58	45	2012	50	97	45	32	211	167	54	16	12,5
D 90	28	70	112	63,5	49	2517	60	108	59,5	45	2517	60	108	59,5	45	235	188	60	16	13,5
D 100	32	80	125	70,5	56	3020	75	120	65,5	51	2517	60	113	59,5	45	254	216	62	16	13,5
D 110	30	90	128	75,5	63	3020	75	134	63,5	51	3020	75	134	63,5	51	279	233	62	16	12,5
D 120	38	100	143	84,5	70	3525	100	140	79,5	65	3020	75	140	65,5	51	314	264	67	16	14,5
D 140	75	130	178	110,5	94	3525	100	178	81,5	65	3525	100	178	81,5	65	359	311	73	17	16
D 160	75	140	187	117	102	4030	115	197	92	77	4030	115	197	92	77	402	345	78	19	15
D 180	75	150	200	137	114	4535	125	205	112	89	4535	125	205	112	89	470	398	94	19	23
D 200	85	150	200	138	114	4535	125	205	113	89	4535	125	205	113	89	508	429	103	19	24
D 220	85	160	218	154,5	127	5040	125	223	129,5	102	5040	125	223	129,5	102	562	474	118	20	27,5
D 250	85	190	254	161,5	132	-	-	-	-	-	-	-	-	-	-	628	532	125	25	27,5

- > 1) Drill holes H7 with keyway in accordance with DIN 6885/1; tolerance zone JS9 and set screws on the keyway

Technical data

Size	Max. rotational speed. rpm	Torque ¹⁾ Nm			Torsion spring rigidity dyn Nm/rad	Relative damping ψ	Moments of inertia ³⁾ kg ²	Weight ³⁾	Max. shaft misalignment ⁴⁾		
		nominal T_{KN}	max T_{kmax}	changing T_{Kw} ²⁾					radial ΔK_r mm	axiale ΔK_a mm	angular ΔK_w mm
D 40	4500	24	64	11	285	0,9	0,00148	1,6	1,1	1,3	5,7
D 50	4500	66	160	26	745	0,9	0,0023	2,4	1,3	1,7	7
D 60	4000	127	318	53	1500	0,9	0,0104	4,0	1,6	2,0	8,7
D 70	3600	250	487	81	2350	0,9	0,018	6,2	1,9	2,3	10
D 80	3100	375	759	127	3600	0,9	0,036	9,8	2,1	2,6	12
D 90	3000	500	1096	183	5200	0,9	0,062	14,0	2,4	3,0	13
D 100	2600	675	1517	252	7200	0,9	0,11	20,0	2,6	3,3	15
D 110	2300	875	2137	356	10000	0,9	0,156	23,5	2,9	3,7	16
D 120	2050	1330	3547	591	17000	0,9	0,274	33,0	3,2	4,0	18
D 140	1800	2325	5642	940	28000	0,9	0,51	45,0	3,7	4,6	22
D 160	1600	3770	9339	1556	44500	0,9	0,849	68,0	4,2	5,3	24
D 180	1500	6270	16455	2742	78500	0,9	1,718	92,0	4,8	6,0	28
D 200	1300	9325	23508	3918	110000	0,9	2,582	112,0	5,3	6,6	30
D 220	1100	11600	33125	5521	160000	0,9	4,246	152,0	5,8	7,3	33
D 250	1000	14675	42740	7124	200000	0,9	7,01	208,0	6,6	8,2	37

- > 1) Torques for shaft fit with keyway
- 2) Maximum alternating torque up to $f = 10\text{Hz}$
- 3) The details of weight and moments of mass inertia apply for medium holes

- 4) The values mentioned are may occur only seperately. At multiple misalignments the values must be reduced (see page 5).

Taper-bushes with keyway acc. to DIN 6885/1

Tolerance JS9

Taper-bush No.	Bore ϕ of available Taper-bushes mm											
	10	11	12	14	16	18	19	20	22	24*	25*	28
1008	10	11	12	14	16	18	19	20	22	24*	25*	28
1210	10	11	12	14	16	18	19	20	22	24	25	28
1610	14	16	18	19	20	22	24	25	28	30	32	35
2012	14	16	18	19	20	22	24	25	28	30	32	35
2517	16	18	19	20	22	24	25	28	30	32	35	38
3020	25	28	30	32	35	38	40	42	45	48	50	55
3525	35	38	40	42	45	48	50	55	60	65	70	75
4030	40	42	45	48	50	55	60	65	70	75	80	85
4535	55	60	65	70	75	80	85	90	95	100	105	110
5040	70	75	80	85	90	95	100	105	110	115	120	125

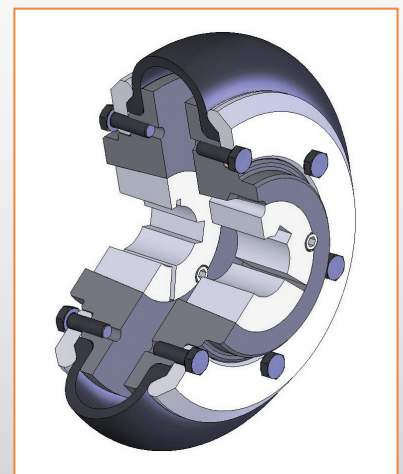

- > * These borholes are with flat - keyway DIN 6885/3

Allowable misalignments

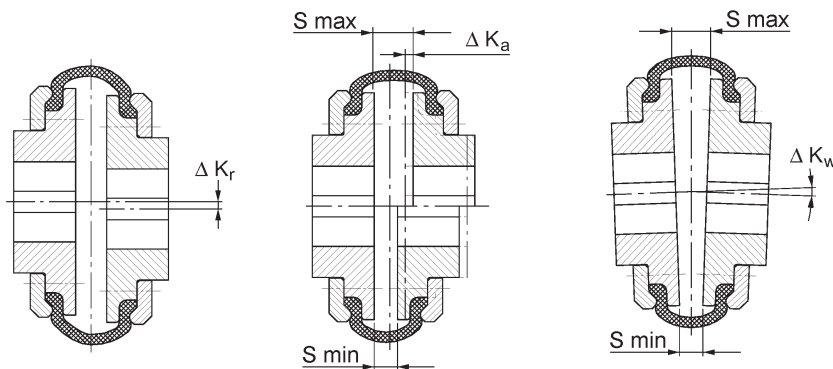

> $\Delta K_{r/a/W}$ = allowable radial, axial or angular misalignment of the shafts resp. of the coupling-halves

- > Radial misalignment
- > Axial misalignment
- > Angular misalignment

> The values given for $\Delta K_W [\text{mm}] = S_{\text{max}} - S_{\text{min}}$ (see page 4) correspond to a angular offset of $\Delta K_W = 4^\circ$. This permissible angular shaft offset is the largest angular offset of the coupling halves, which may only be fully utilised if there is no axial and radial offset. An angular offset of $\Delta K_W = 2^\circ$ is permissible if axial and radial offsets of $1/2 \Delta K_a$ and $1/2 \Delta K_r$ are present.

Selection

The torque of the machine T_{AN} is determined by: $T_{AN} [\text{Nm}] = 9550 \times \frac{P_{\text{Motor}} [\text{kW}]}{n [\text{rpm}]}$

This torque T_{AN} multiplied by a safety factor S depending on the application (see table page 7) gives the required nominal coupling torque T_{KN} .

Result: $T_{KN} \geq S \times T_{AN}$

- > In case that bigger shock or changing load occur we recommend a revision according to DIN 740. An adequate calculation program is available. For such a revision the following information is required:
 1. Kind of the driving machine
 2. Kind of the driven machine
 3. Power of driving and driven machines
 4. Rotational speed of operation
 5. Shock loads
 6. Exciting loads
 7. Moments of inertia of load- and driving sides
 8. Starts per hour
 9. Ambient temperature

Design example for IEC standard motors

Dates of the plant

Driving machine: Three-phase motor 280 S
 Power of the motor $P = 75 \text{ kW}$
 Rotation at speed $n = 1500 \text{ rpm}$
 up to 50 start-ups per hour
 Driven machine: Mixer
 Ambient temperature: $+ 25 \text{ }^\circ\text{C}$

Layout of the coupling

$$T_{AN} [\text{Nm}] = 9550 \times \frac{75 \text{ kW}}{1500 \text{ rpm}} = 478 \text{ Nm}$$

$$T_{KN} = 2,5 \times 478 \text{ Nm} = 1195 \text{ Nm}$$

($S = 1.75$ as per Table +0.75 for start-up frequency greater than 25)

Selection: DESCH Flex D 120

$$T_{KN} = 1330 \text{ Nm}$$

Allocation to IEC motor

Power P of the IEC motor and allocated DESCH Flex					Shaft ends					
Size of the three phase motor	3000 rpm		1500 rpm		1000 rpm		750 rpm		Form E DIN 748 part 3 d x l at speed approx.	
	P kw	Flex Size	P kw	Flex Size	P kw	Flex Size	P kw	Flex Size	3000 rpm	1500 rpm and less
56	0,09	D40	0,06	D40	0,037	D40	--		9 x 20	
	0,12	D40	0,09	D40	0,045	D40				
63	0,18	D40	0,12	D40	0,06	D40	--		11 x 23	
	0,25	D40	0,18	D40	0,09	D40				
71	0,37	D40	0,25	D40	0,18	D40	0,09	D40	14 x 30	
	0,55	D40	0,37	D40	0,25	D40	0,12	D40		
80	0,75	D40	0,55	D40	0,37	D40	0,18	D40	19 x 40	
	1,1	D40	0,75	D40	0,55	D40	0,25	D40		
90 S	1,5	D50	1,1	D50	0,75	D50	0,37	D50	24 x 50	
90 L	2,2	D50	1,5	D50	1,1	D50	0,55	D50	24 x 50	
100 L	3	D50	2,2	D50	1,5	D50	0,75	D50	28 x 60	
	--		3	D50	--		1,1	D50		
112 M	4	D50	4	D50	2,2	D50	1,5	D50	28 x 60	
132 S	5,5	D60	5,5	D60	3	D60	2,2	D60	38 x 80	
	7,5	D60	--		--		--			
132 M	--		7,5	D60	4	D60	3	D60	38 x 80	
	--		--		5,5	D60	--			
160 M	11	D70	11	D70	7,5	D70	4	D70	42 x 110	
	15	D70	--		--		5,5	D70		
160 L	18,5	D70	15	D70	11	D70	7,5	D70	42 x 110	
180 M	22	D70	18,5	D70	--		--		48 x 110	
180 L	--		22	D70	15	D80	11	D80	48 x 110	
200 L	30	D80	30	D80	18,5	D80	15	D80	55 x 110	
	37	D80	--		22	D80	--			
225 S	--		37	D90	--		18,5	D90	55 x 110	60 x 140
225 M	45	D80	45	D100	30	D100	22	D100	55 x 110	60 x 140
250 M	55	D80	55	D100	37	D100	30	D100	60 x 140	65 x 140
280 S	75	D80	75	D110	45	D110	37	D120	65 x 140	75 x 140
280 M	90	D90	90	D120	55	D120	45	D120	65 x 140	75 x 140
315 S	110	D100	110	D120	75	D120	55	D120	65 x 140	80 x 170
315 M	132	D110	132	D140	90	D140	75	D140	65 x 140	80 x 170
	160	D120	160	D140	110	D140	90	D140	65 x 140	80 x 170
315 L	200	D120	200	D140	132	D140	110	D160	65 x 140	80 x 170
	250	D140	250	D160	160	D160	132	D180	75 x 140	95 x 170
	315	D140	315	D160	200	D160	160	D180	75 x 140	95 x 170
355 L	--		--		250	D160	200	D180	75 x 140	95 x 170
	355	D140	355	D180	315	D180	250	D180	80 x 170	100 x 210
	400	D140	400	D180	--		--		80 x 170	100 x 210

> As proposed in the table for surface cooled three-phase motors with cage rotor acc. to DIN 42673, (data for motor 56, 63, 71, 80, 315 L, 355 L, 400 L, see catalogue Siemens). This allocation is a preliminary selection for normal conditions of operation. For conditions of operation under shock and changing loads the selection must be made according to page 5.

Safety factors “S”

Assignment of load characteristics according to type of working machine

S	DREDGERS	S	BUILDING MACHINERY	S	Suction rolls
S	Bucket conveyor	G	Hoists	S	Drying cylinders
M	Landing gear (caterpillar)	S	Concrete mixers		
M	Landing gear (rail)		Road construction machinery		PUMPS
M	Manoeuvring winches			S	Piston pumps
M	Pumps		RUBBER MACHINERY	G	Centrifugal pumps (light liquids)
S	Impellers	S	Extruders	M	Centrifugal pumps (viscous liquids)
S	Cutter heads	M	Calenders	S	Plunger pumps
M	Slewing gear	S	Kneading mill	S	Press pumps
		M	Mixers		
	GENERATORS, TRANSFORMERS	S	Rolling mills		STONE AND CLAY WORKING MACHINES
M	Frequency transformers			S	Crusher
M	Generators		WOOD WORKING MACHINES	S	Rotary ovens
M	Welding generators	S	Barkers	S	Hammer mills
		M	Planing machines	S	Ball mills
	CHEMICAL INDUSTRY	G	Wood working machines	S	Tube mills
M	Cooling drums	S	Saw frames	S	Beater mills
M	Mixers			S	Brick presses
G	Agitators (liquid material)		CRANES		TEXTILE MACHINES
M	Agitators (semi-liquid material)	G	Luffing gear block		Batchers
M	Drying drums	S	Travelling gear	M	Printing and dyeing machines
G	Centrifuges (light)	G	Hoist gear	M	Tanning vats
M	Centrifuges (heavy)	M	Slewing gear	M	Willows
		M	Derricking jib gear	M	Looms
	OIL INDUSTRY				COMPRESSORS
M	Pipeline pumps		PLASIC INDUSTRY MACHINES	S	Piston compressors
S	Rotary drilling equipment	M	Extruders	M	Turbo compressors
		M	Calenders		
	CONVEYORS	M	Mixers		METAL ROLLING MILLS
M	Pit-head winches	M	Crushers	S	Plate shears
S	Winding engines			M	Manipulator for turning sheets
M	jointed-band conveyors		METAL WORKING MACHINES	S	Ingot pushers
G	Belt conveyors (bulk material)	M	Plate bending machines	S	Ingot and slabbing-mill train
M	Belt conveyors (piece goods)	S	Plate straightening machines	S	Ingot handling machinery
M	Band pocket conveyors	S	Hammers	M	Wire drawing benches
M	Chain conveyors	S	Metal planning machines	S	Descaling machines
M	Circular conveyors	S	Presses	S	Thin plate mills
M	Load elevators	M	Shears	S	Heavy and medium plate mills
G	Bucket conveyors for flour	S	Forging presses	M	Winding machines (strip and wire)
M	Passenger lifts	S	Punch presses	S	Cold rolling mills
M	Plate conveyors	G	Countershafts, line shafts	M	Chain tractor
M	Screw conveyors	M	Machine tools (main drives)	S	Billet shears
M	Ballast elevators	G	Machine tools (auxiliary drives)	M	Cooling beds
S	Inclined hoists			M	Cross tractor
M	Steel belt conveyors		FOOD INDUSTRY MACHINERY	M	Roller tables (light)
M	Drag chain conveyors	G	Bottling and container filling machines	S	Roller tables (heavy)
		M	Kneading machines	M	Roller straighteners
	BLOWERS, VENTILATORS	M	Mash tubs	S	Tube welding machines
G	Rotary piston blowers T 75 Nm	G	Packaging machines	M	Trimming shears
M	Rotary piston blowers T 750	M	Cane crushers	S	Cropping shears
S	Rotary piston blowers T 750 Nm	M	Cane cutters	S	Continuous casting plant
G	Blowers (axial/radial) T 75 Nm	S	Cane mills	M	Rollers adjustment drive
M	Blowers (axial/radial) T 750	M	Sugar beet cutters	S	Manipulators
S	Blowers (axial/radial) T 750 Nm		Sugar beet washing machines		
G	Cooling tower fans T 75 Nm				LAUNDRIES
M	Cooling tower fans T 750	S	PAPER MACHINES	M	Tumblers
S	Cooling tower fans T 750 Nm	M	Couches	M	Washing machines
G	Induced draught fans T 75 Nm	S	Glazing cylinders		
M	Induced draught fans T 750	M	Pulper		WATER TREATMENT
S	Induced draught fans T 750 Nm	S	Pulp grinders	M	Aerators
G	Turbo blowers T 75 Nm	M	Calenders	M	Screw pumps
M	Turbo blowers T 750	S	Wet presses		
S	Turbo blowers T 750 Nm	S	Willows		
		S	Suction presses		

Driving machines	Operating factor “S”		
	Load characteristics of the working machine		
	G	M	S
Electric motors, turbines, hydraulic motors	1	1,75	2,5
Piston machines 4-6 cylinders, degree of nonuniformity 1:100 - 1:200	1,25	2	2,75
Piston machines 1-3 cylinders, degree of nonuniformity up to 1:100	1,5	2,25	3

➤ The operating factor S takes account of up to 25 start-ups per hour. With up to 120 start-ups per hour the factor S must be increased by 0.75.



DESCH Antriebstechnik GmbH & Co. KG

Postbox 14 40 | 59753 Arnsberg/Germany
Kleinbahnstraße 21 | 59759 Arnsberg/Germany
T +49 2932 300 0 | F +49 2932 300 899
I www.desch.de | E info@desch.de

DESCH DPC GmbH & Co. KG
Postbox 14 40
59753 Arnsberg/Germany
Kleinbahnstraße 21
59759 Arnsberg/Germany
T +49 2932 300 0
F +49 2932 300 830
I www.desch.de
E info@desch.de

DESCH Canada Ltd.
240 Shearson Crescent
Cambridge, Ontario
Canada N 1T 1J6
T +1800 2631866
+1519 6214560
F +1519 6231169
I www.desch.de
E desch@desch.on.ca

DESCH Italia
Drive Technology
Ufficio di rappresentanza in Italia
Via Cavriana, 3
20134 Milano/Italy
T +3902 7391280
F +3902 7391281
I www.desch.de
E desch.italia@desch.de

DESCH China
Machinery (Shanghai) Ltd.
No.10 Building, No.2317
Shengang Road, Songjiang District
201612 Shanghai/China
T +86 21 5771 8058 818
F +86 21 5765 5155
I www.desch.de
E desch.china@desch.de