

Clamping Elements Type RCK 16

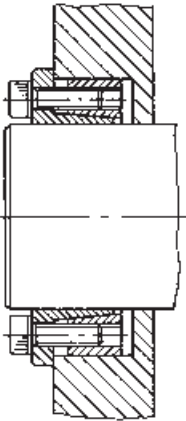

These clamping elements are basically to same design as RCK 13, but with increased diameter flange to locate hub and prevent axial movements, so combining good concentricity with positive axial location. The increase in friction between the cones due to axial restriction results in torque reduction of approx 20%, but this also means reduced surface pressures to both hub and shaft.



Recommended tolerances for full torque transmission are:-

Shaft h8
Hub H8

Clamping surfaces to be finished to $Rz \leq 15 \mu\text{m}$.

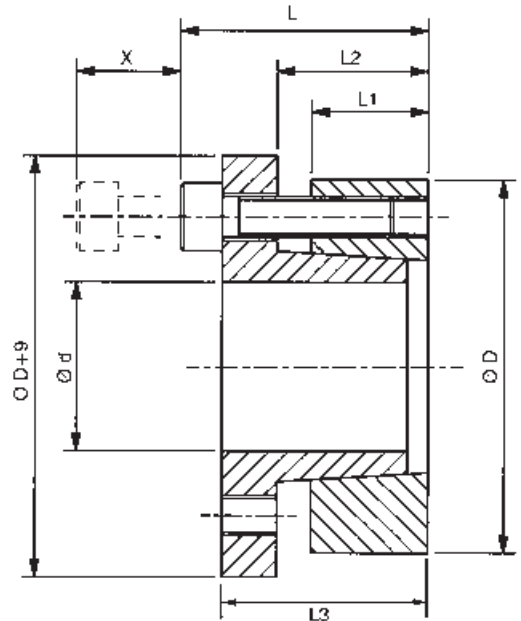

X = Distance required to remove screws, additional clearance for alan key may be required.

Dimensions

Part No.	Dimensions mm							Torque Cap. M Nm	Axial Force F kN	Surface Pressure		Clamping Screws		Approx. Weight kg	Min. Hub Dia* mm		
	d	D	L	L ₁	L ₂	L ₃	X			Shaft Ps N/mm ²	Hub Ph N/mm ²	Size	Torque Nm		Assy Type A	Assy Type B	Assy Type C
RCK16-18x47	18	47	34	17	22	28	20	264	29	215	93	M6	17	0.28	63	60	56
RCK16-19x47	19	47	34	17	22	28	20	274	29	215	93	M6	17	0.27	63	60	56
RCK16-20x47	20	47	34	17	22	28	20	284	28	215	93	M6	17	0.26	63	60	56
RCK16-22x47	22	47	34	17	22	28	20	314	29	196	93	M6	17	0.25	63	60	56
RCK16-24x50	24	50	34	17	22	28	20	401	33	215	107	M6	17	0.28	71	66	61
RCK16-25x50	25	50	34	17	22	28	20	441	35	210	107	M6	17	0.27	71	66	61
RCK16-28x55	28	55	34	17	22	28	20	490	35	196	98	M6	17	0.35	75	71	66
RCK16-30x55	30	55	34	17	22	28	20	529	35	186	98	M6	17	0.32	75	71	66
RCK16-32x60	32	60	34	17	22	28	20	755	47	210	112	M6	17	0.38	86	80	74
RCK16-35x60	35	60	34	17	22	28	20	824	47	186	107	M6	17	0.35	85	79	74
RCK16-38x65	38	65	34	17	22	28	20	892	47	191	112	M6	17	0.41	94	87	80
RCK16-40x65	40	65	34	17	22	28	20	941	47	186	102	M6	17	0.39	90	84	79
RCK16-45x75	45	75	41	20	25	33	25	1716	76	225	132	M8	41	0.65	116	106	97
RCK16-50x80	50	80	41	20	25	33	25	1893	76	205	127	M8	41	0.69	122	111	102
RCK16-55x85	55	85	41	20	25	33	25	2403	87	210	132	M8	41	0.75	132	120	109
RCK16-60x90	60	90	41	20	25	33	25	2648	88	186	122	M8	41	0.80	134	123	114
RCK16-65x95	65	95	41	20	25	33	25	3188	98	196	132	M8	41	0.85	147	134	122
RCK16-70x110	70	110	50	24	30	40	30	4905	140	215	137	M10	83	1.35	174	157	143
RCK16-75x115	75	115	50	24	30	40	30	5150	137	195	127	M10	83	1.42	175	160	147
RCK16-80x120	80	120	50	24	30	40	30	5490	137	185	122	M10	83	1.51	179	164	151
RCK16-85x125	85	125	50	24	30	40	30	6620	156	195	132	M10	83	1.58	194	176	161
RCK16-90x130	90	130	50	24	30	40	30	6960	155	185	127	M10	83	1.66	198	181	166
RCK16-95x135	95	135	50	24	30	40	30	8190	172	195	137	M10	83	1.73	213	193	176
RCK16-100x145	100	145	56	26	32	44	35	10100	202	205	145	M12	145	2.64	236	212	192
RCK16-110x155	110	155	56	26	32	44	35	11030	201	190	135	M12	145	2.84	243	220	201
RCK16-120x165	120	165	56	26	32	44	35	13600	227	205	142	M12	145	3.05	266	239	217
RCK16-130x180	130	180	64	34	40	52	35	19000	292	186	137	M12	145	4.70	284	257	234
RCK16-140x190	140	190	68	34	40	54	40	21800	311	177	127	M14	230	4.95	289	264	242
RCK16-150x200	150	200	68	34	40	54	40	25600	341	185	130	M14	230	5.30	308	280	256
RCK16-160x210	160	210	68	34	40	54	40	31300	391	174	150	M14	230	5.60	349	311	280
RCK16-170x225	170	225	78	44	49	64	50	33200	391	147	110	M14	230	7.90	322	298	277
RCK16-180x235	180	235	78	44	49	64	50	35000	389	139	100	M14	230	8.30	325	303	284
RCK16-190x250	190	250	78	44	49	64	50	46500	489	132	120	M14	230	8.80	371	341	314
RCK16-200x260	200	260	78	44	49	64	50	49000	500	125	110	M14	230	9.20	372	345	321
RCK16-220x285	220	285	88	51	57	72	55	57100	519	132	97	M16	360	12.30	390	365	343
RCK16-240x305	240	305	88	51	57	72	55	77800	649	134	113	M16	360	13.30	441	408	378
RCK16-260x325	260	325	88	51	57	72	55	101200	778	145	127	M16	360	14.30	495	452	414
RCK16-280x355	280	355	102	60	66	84	65	113300	808	120	101	M18	480	21.00	492	460	430
RCK16-300x375	300	375	102	60	66	84	65	136500	910	123	107	M18	480	22.20	531	493	460

*Minimum outside diameter of hubs manufactured in medium carbon steels with yield strength $\geq 320 \text{ N/mm}^2$.

For hub types, and other materials, refer to page 3.

For assembly and disassembly instructions refer to page 24.